

Eicher Pro 6016
The 16T GVM Heavy Duty Freight Carrier

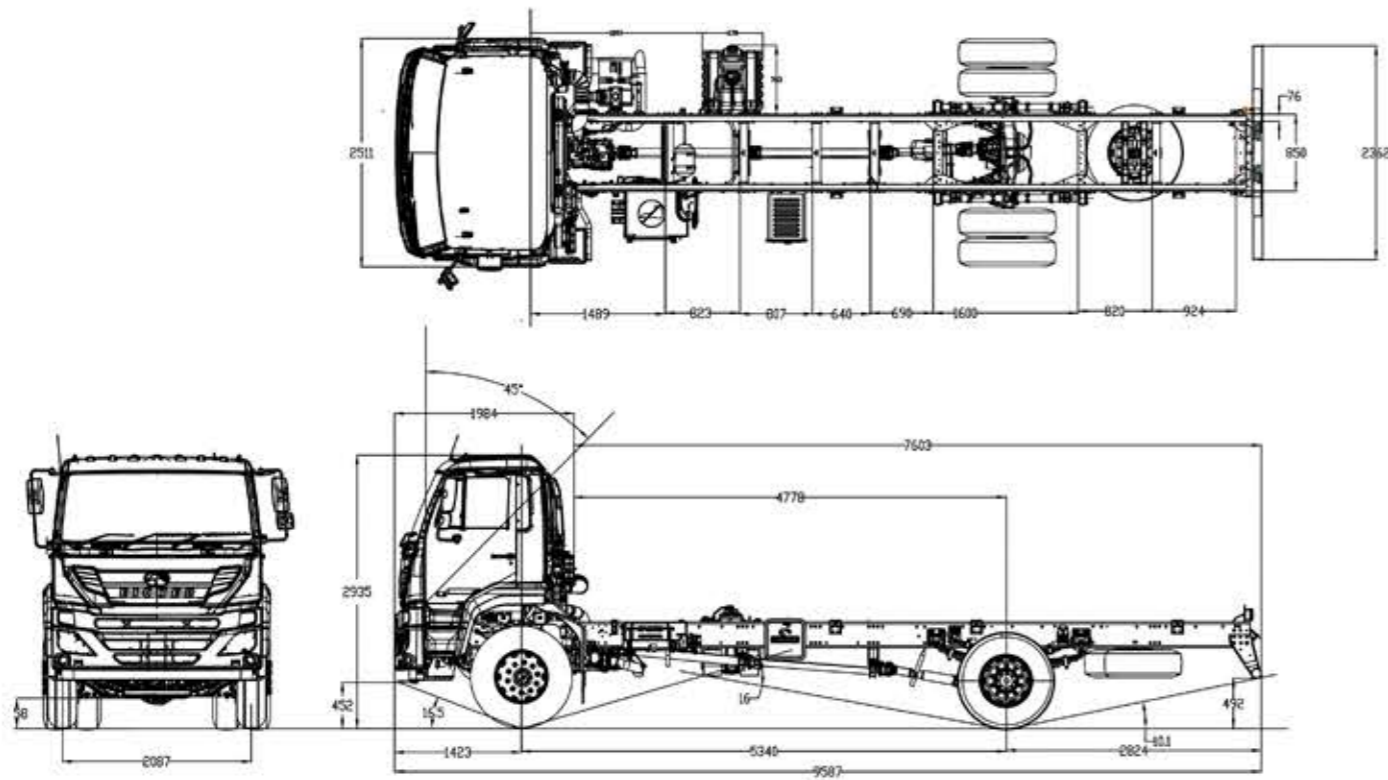

VE COMMERCIAL VEHICLES
A VOLVO GROUP AND EICHER MOTORS JOINT VENTURE

VECV SOUTH AFRICA (PTY.) LIMITED
Registration Number- 2016/007012/07
Unit 15 Cambridge Office Park, 5 Bauhinia Street,
Highveld Technopark, Centurion, South Africa.
Tel: +27 825568366, +27 761646340
www.eicher.co.za

Eicher Pro 6016
The 16T GVM Heavy Duty Freight Carrier

TRUCKS AND BUSES

**BORN
EFFICIENT**



**VOLVO GROUP ENGINE
MANAGEMENT SYSTEM 3.0
CABIN ADAPTED FROM JAPANESE DESIGN,
MEETS AIS 029 SAFETY STANDARDS**



PARTNERSHIP WITH THE VOLVO GROUP

Two leading players in the commercial vehicle business joined hands in 2008 with a convergent vision of driving modernization in commercial transportation. Volvo Group, the world's leading manufacturer of trucks, buses, construction equipments and marine and industrial engines, brought in its global expertise and world-class technology, while Eicher Motors brought in its innovative engineering and proven DNA of fuel efficiency. The Eicher Pro Series, a range of next generation trucks & buses, is a culmination of this joint venture

THE PRO LEAGUE OF TRUCKING

Eicher introduces the all new Pro Series in South African market, a range of new generation trucks and buses designed and developed to usher in a Pro League, incorporating Volvo Group's world class technology & processes supported with South African After-sales Care.

TESTED & BUILT FOR SOUTH AFRICA

Eicher Pro 6000 Series is tested across Asia and Africa through various terrains and climates.

INTRODUCING THE PRO 6000 SERIES IN SOUTH AFRICA



GLOBAL TECHNOLOGY



GLOBAL TECHNOLOGY MEETS INNOVATIVE ENGINEERING

The Eicher Pro Series has been designed and developed in a modern, high-tech and multi-facility manufacturing plant, which also houses a next-generation engine plant, built in collaboration with the Volvo Group. It not only manufactures Euro IV heavy-duty engines but also supplies Euro VI compliant automotive engines internationally, to the Volvo Group.

GLOBAL BENCHMARK MANUFACTURING PLANT

The completely new chassis and assembly line have been designed to balance global technology and processes with innovative engineering. The state-of-the-art manufacturing process which includes a robotic cab weld shop, CED paint shop and a 100% hot test facility, ensures quality and reliability of international standards.

Eicher Pro 6016 BORN EFFICIENT

Eicher Pro 6016 has been designed and developed to provide unparalleled business advantage by maximizing efficiency right through the life-cycle of the vehicle and minimizing the cost of operations. The Eicher Pro 6000 is a range of next generation heavy duty trucks-haulage and tippers, ranging from 16 to 25 ton GVM. The new range is geared to revolutionize the levels of productivity in the heavy-duty trucking industry, with the infusion of international engine technology and cabin design from the Volvo Group, together with the intelligent features and South African after-sales support. The contemporary exterior styling with the signature Pegasus grill design and sleek cabin interiors give the trucks a dynamic look.

MAXIMUM EFFICIENCY DELIVERED THROUGH:

- **CLASS-LEADING FUEL EFFICIENCY**
- **BEST IN CLASS TORQUE**
- **SUPERIOR UPTIME**
- **CABIN ADAPTED FROM JAPANESE DESIGN FOR COMFORT, SAFETY & EFFICIENCY**
- **LOW & EASY MAINTENANCE**
- **INTELLIGENT DRIVER INFORMATION SYSTEM**



CLASS-LEADING FUEL EFFICIENCY

HIGH PERFORMANCE. LOW FUEL CONSUMPTION.

VEDX5 ENGINE-DESIGNED IN ASSOCIATION WITH THE VOLVO GROUP

Designed in collaboration with the Volvo Group, the next generation VEDX5 engine is powered with 5.1 litre CRS technology. The 4 cylinder, 4 valve engine has high combustion efficiency and low parasitic losses that delivers best-in-class 210 HP and 825 NM torque, resulting in class leading fuel efficiency.



FIE SYSTEM WITH ADVANCED JAPANESE TECHNOLOGY

The highly robust and reliable Japanese FIE-Fuel Injection Equipment system delivers highest sustained fuel pressures maintaining optimum fuel economy.



EMS 3.0- VOLVO GROUP'S ENGINE MANAGEMENT SYSTEM

Volvo Group's EMS 3.0 has high processing capability and maintains optimum balance between load demand, fuel efficiency and emission control.

BEST-IN-CLASS PRODUCTIVITY

FASTER TURNAROUND. MORE TRIPS.

POWER-PACKED DRIVELINE

Robust, rigorously tested and highly durable driveline with best-in-class aggregates delivers more power and higher torque. Quick gear shifts and minimal RPM and torque disruption, enables better pick-up, while one of the best-in-class torque to weight ratio ensures outstanding gradeability.

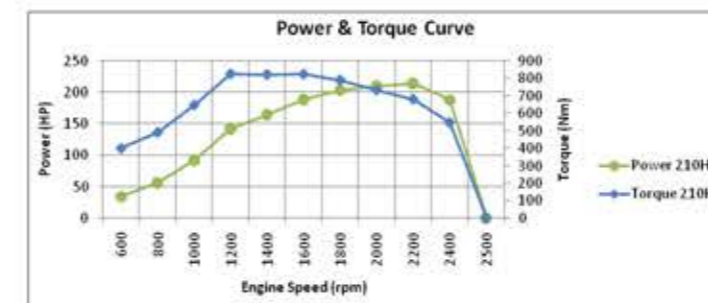
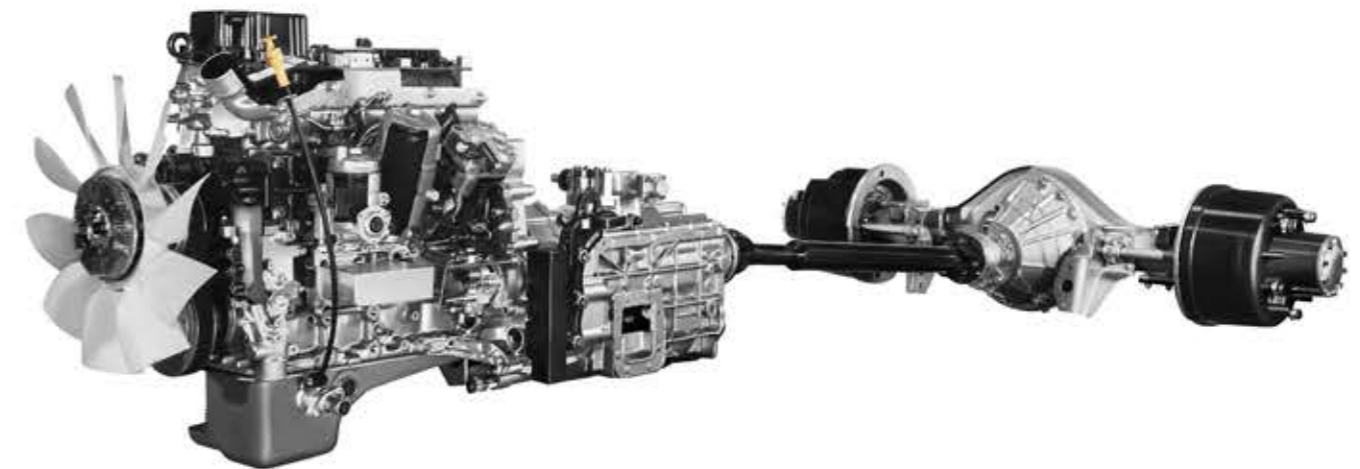

FLAT TORQUE CURVE

The driveline is designed to deliver peak torque at wide range of RPM (1200-1600 RPM) which facilitates better operations in all terrains. Availability of high torque at lower engine RPM necessitates lesser gear shifts enhancing fuel efficiency.

The image shown is just a representative of the actual aggregates.

SUPERIOR UPTIME

BUILT TO LAST ROBUST AGGREGATES

Global technology coupled with advanced design and manufacturing processes ensures highly reliable and durable aggregates, translating into unmatched L10 life. The use of higher strength, lower weight composite materials derive maximum life from each component which makes sure the truck is on road and available for work.



DOMEX CHASSIS

- Chassis with high tensile strength (650 mpa).
- All long members and cross members are CED painted for long life.



ADVANCED ON BOARD DIAGNOSTICS

Advanced diagnostics system throws up fault indicators to the driver in the form of visual signals, messages and alarms to check for probable causes and take corrective action. Together with the fully equipped Eicher service network, preventive and corrective maintenance of the tipper is ensured, thus delivering superior uptime.



ENGINE THAT PROTECTS ITSELF

- EPS - Protection against engine overheating due to low oil pressure, high coolant temperature, fuel leak etc.
- Downhill RSL protection
- FIE components protection
- Starter Motor protection



TRANSMISSION

- 395mm diameter clutch
- ET70 6 speed gearbox
- Maximum gradeability of 34.5%



PROPELLER SHAFT

- Cross-serrated shaft
- Lubricated for life for a maintenance free operation



REAR AXLE

- Fully floating Banjo type axle
- Final Drive Ratio optimized at 5.29 for maximizing torque at wheels output

*The image shown is just a representative of the actual aggregates

CABIN ADAPTED FROM JAPANESE DESIGN FOR COMFORT, SAFETY & EFFICIENCY

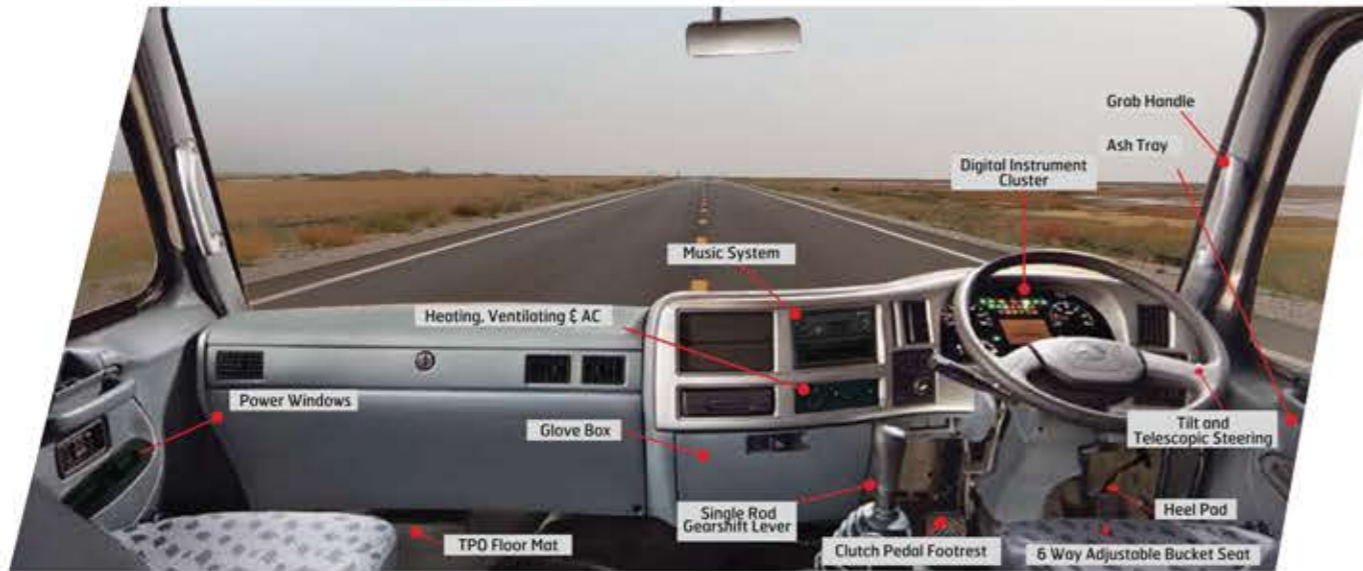

ACTIVE & PASSIVE SAFETY FEATURE



INTELLIGENT DRIVER INFORMATION SYSTEM (IDIS)

The IDIS provides live information to the driver on truck operational parameters, fuel consumption and advanced diagnostics. The information is relayed through tell-tale icons and audible alarms which the driver can easily understand and process. This ensures safe and efficient driving, with preventive vehicle maintenance, leading to minimum drive interruptions. Detailed fuel data, including instantaneous fuel value, average fuel consumption and distance to empty are also shown.



TECHNICAL SPECIFICATION

Eicher Pro 6016 The 16T GVM Heavy Duty Freight Carrier

Model	Pro 6016	Suspension	
Vehicle Weight (Kgs)		Front Suspension	Semi elliptical leaf springs with double acting telescopic shock absorber & Anti-roll bar
GVM	16000	Rear Suspension	Semi elliptical laminated leaf springs
FAW (laden)	7100	Wheels & Tyres	
RAW (laden)	9000	Tyre Size	Tubeless radial 295/80R22.5-16PR
Kerb weight - w/o load body	5930	Wheel Rim size	8.25X22.5
Engine		Cabin	
Model	VEDX5, 4 Cylinder 4 Valve per cylinder, turbo charged, intercooled diesel, common rail	2.3 m Day cab (Premium)	
Capacity	5100 cc	Model	New Pro 6016 HVAC CAB with IDIS
Max Power	210 Hp @ 2200 rpm	Brakes	
Max Torque	825 Nm @ 1200-1600 rpm	Brake type	Dual Circuit, Full Air
Emission	Euro III	Parking brake type	Pneumatic Control, hand operated
Transmission		ABS	Standard
Gear Box	ET70S6 (6 Forward 1 Reverse)	Electrical	
Gear Shift Linkage	Single Rod GSL	Battery	24V,150AH
Clutch		Fuel Tank	
Clutch	395 mm Plate Dia, spring loaded push type	Size	220 litres
Rear Axle		Performance	
Rear Axle Ratio	5.286	Max Speed (kmph)	110
Chassis Frame		Gradeability	34.5%
Type	Ladder type joggle frame	Vehicle Dimensions (mm)	
Section	285 X 76 X 7	Wheel Base	5340
Steering System		FOH	1423
Type	Power steering	ROH	2824
TCD (M)	18	Cabin Width	2300
		Ground Clearance	230

**EICHER
NETWORK
IN SOUTHERN AFRICA**

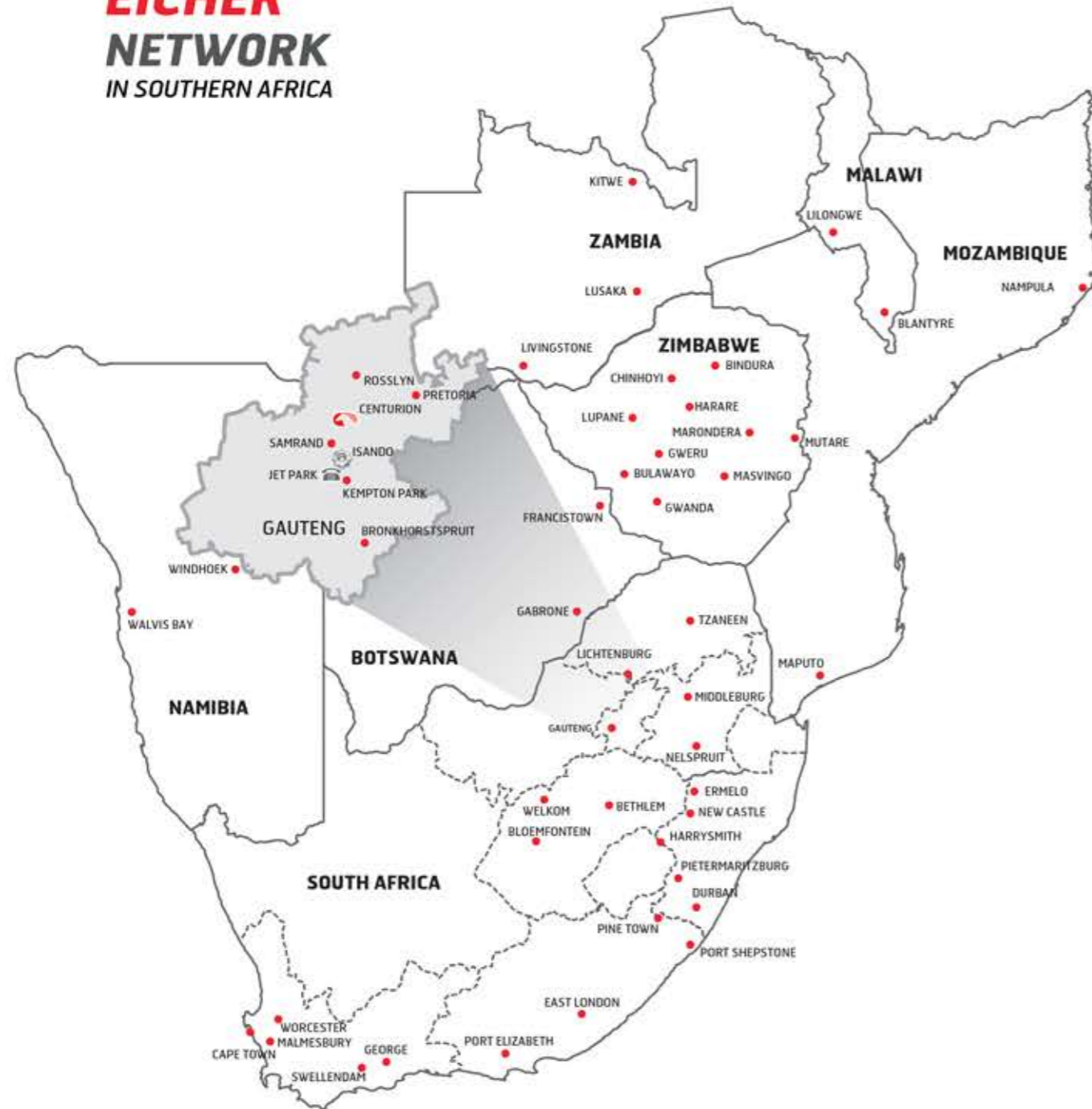

-  VECV South Africa (Pty) Ltd., (Centurion)
-  Eicher Parts Distribution Centre- Supported by Bidvest (Isando)
-  Volvo Group Call Centre (Jet Park)

Eicher has an extensive service reach and no matter where you are, Eicher service is never too far away. Eicher has wide and expanding authorized contact points across the country with professionally trained dealership service teams ensuring your vehicle is in safe hands. Eicher dealers are equipped with mobile service vans and 24x7 helpline numbers to ensure quick response. What's more, Eicher genuine parts made to exact specifications are economical and widely available across Eicher dealers, service centres, spare distributors and other outlets.

**AFTER MARKET
ASSURANCE**

The point of sale is just the beginning of the relationship, which is a commitment to partner the customer right through the entire life cycle of the vehicle.

SERVICE ASSURANCE

COUNTRYWIDE NETWORK

Eicher promises to deliver customer service with unmatched reliability & quality of repairs thru our countrywide dealers network.

TRAINED WORKFORCE

To maintain service quality standards, the workshop teams are trained and certified by Eicher for diagnostics skills and exhaustive knowledge of all our products.

STATE OF ART WORKSHOPS

Workshops are equipped with all modern equipment for quick service State-of-the-art diagnostic system.



PARTS ASSURANCE

PARTS AVAILABILITY

Eicher Parts Distribution Team with help of local warehousing & distribution experts ensures speedy parts supply and minimum delays in delivery of parts to our Dealer Network.

PARTS WARRANTY

With a vision to reduce the perceived performance related issues as well as the financial risk to the customer, Eicher extends a warranty along with Eicher Genuine Parts.

SUPPORT AGGREGATES

To ensure higher uptime of vehicles VECVSA is equipped with support aggregates which will support customer with fit first repair later view.



EICHER CARE

24x7 Eicher call center support to support operator incase vehicle stand immobilized enroute. Fully equipped dealers team ensures quick resolution by enroute breakdown assistance.

Contact: 0800 342 437

